

13 series is designed in strict accordance with the requirements of the mobile machinery industry. Its compact shape can be fully integrated with the hydraulic cylinder with limited head space. The high versatile IP68 profile housing offers full protection for use in harsh environments with high contamination and presence of dust. If the hydraulic cylinder is used with a special connector, the protection level is up to IP69K. Vibration and shock rating are also high-level 25g / 10-2000Hz and 100g (single shock).

It adopts the non-contact magnet-rostrictive measuring technology for precise, accurate, and absolute measurement. The non-contact feature provides exceptional ease of installation and guarantees almost unlimited mechanical life expectancy.



Specifications

Order Code	13 C
Output	Voltage / Current
Measurement Type	Linear displacement
Resolution	<500mm ±0.10mm, 700mm ±0.18mm, 1000mm ±0.24mm 1250mm ±0.30mm, 1750mm ±0.42mm,
Repeatability	< ±0.005% of full scale
Non-Linearity	< ±0.04% of full scale (minimum ±100µm for 60mm damping zone) < ±0.08% of full scale (for 36.5mm damping zone)
Input Voltage	+12V / +24Vdc
Input Protection	Polarity protection up to -30Vdc, Over voltage protection up to 36Vdc
Power Consumption	1W
Dielectric Strength	500Vdc (DC ground to machine ground)
Operation Temp.	-40 to 85°C, Humidity 90% non-condensing
Sealing	IP 68 (IP 69K when installed inside a cylinder with M12x1 connection type)
Vibration Rating	25g / 10-2000Hz / IEC standard 68-2-6
Shock Rating	100g single hit per IEC standard 68-2-27
EMC	Emission EN 61000-6-3, Immunity EN 61000-6-2, EN 61000-4-2/3/4/6
Pressure Rating	300 bar / 400 bar peak
Material	Stainless Steel



Order Code

1 3 C X X X X X X X X X X X X X X

Output

011 = 0.25 - 4.75V 101 = 4 - 20mA
 012 = 0.5 - 4.5V 104 = 20 - 4mA
 013 = 4.75 - 0.25V
 014 = 4.5 - 0.5V

Connection Type

N__A = 4 single wires (20AWG)
 N__E = 4 single wires , M12x1 IP69K,4pin (pin assignment 2-3-4)
 N__G = 4 single wires , M12x1 IP69K,4pin (pin assignment 1-3-4)
 N__H = 4 single wires , M12x1 IP69K,4pin (pin assignment 1-2-3)
 Ex. : 06 = 60mm wire length
 25 = 250mm wire length
 T__A = integral PUR shielded cable, pigtail for wire termination
 Ex. : 10 = 1.0 meter cable length (0.5 meter mini.)
 35 = 3.5 meter cable length

Sensor Styles

1 = 7 mm dia. rod, damping zone 60mm
 2 = 7 mm dia. rod, damping zone 36.5mm
 3 = 10 mm dia. rod, damping zone 36.5mm

Magnet Type

1 = Outer dia. 33mm, inner dia. 13.5 ring magnet
 2 = Outer dia. 25.4mm, inner dia. 13.5 ring magnet
 3 = Outer dia. 17.4mm, inner dia. 13.5 ring magnet

Stroke Length (mm)

0075, 0100, 0125, 0150, 0175, 0200, 0225
 0250, 0275, 0300, 0325, 0350, 0375, 0400
 0425, 0450 (25mm increment after)

Pin Assignments

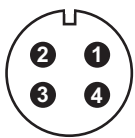

4 pin M12 A model
 (View toward sensor pins)

	Color	N__E
1	Yellow	N.C.
2	Brown	12/24 Vdc
3	White	0 Vdc
4	Green	Output

	Color	N__G
1	Brown	12/24 Vdc
2	Yellow	N.C.
3	White	0 Vdc
4	Green	Output

	Color	N__H
1	Brown	12/24 Vdc
2	Green	Output
3	White	0 Vdc
4	Yellow	N.C.

Cable Assignments

	Color	N__A
	Brown	12/24 Vdc
	Green	Output
	Yellow	N.C.
	White	0 Vdc

	Color	T__A
	Red	12/24 Vdc
	Green	Output
	Yellow	N.C.
	Black	0 Vdc

Specifications

Order Code	13 C
Output	Direct CANopen or CAN J1939
Measurement Type	Linear displacement
Resolution	<500mm ±0.10mm, 700mm ±0.18mm, 1000mm ±0.24mm 1250mm ±0.30mm, 1750mm ±0.42mm,
Repeatability	< ±0.005% of full scale
Non-Linearity	< ±0.04% of full scale (minimum ±100µm for 60mm damping zone) < ±0.08% of full scale (for 36.5mm damping zone)
Input Voltage	+12V / +24Vdc
Input Protection	Polarity protection up to -30Vdc, Over voltage protection up to 36Vdc
Power Consumption	1W
Dielectric Strength	500Vdc (DC ground to machine ground)
Operation Temp.	-40 to 85°C, Humidity 90% non-condensing
Sealing	IP 68 (IP 69K when installed inside a cylinder with M12x1 connection type)
Vibration Rating	25g / 10-2000Hz / IEC standard 68-2-6
Shock Rating	100g single hit per IEC standard 68-2-27
EMC	Emission EN 61000-6-3, Immunity EN 61000-6-2, EN 61000-4-2/3/4/6
Pressure Rating	350 bar / 530 bar peak
Material	Stainless Steel

Pin Assignments

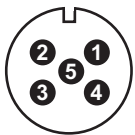

5 pin M12 A model
(View toward sensor pins)

	Color	N__F
1	N.C.	N.C.
2	Brown	12/24 Vdc
3	White	0 Vdc
4	Yellow	CAN High
5	Green	CAN Low

Cable Assignments

Color	N__A
Brown	12/24 Vdc
Green	CAN Low
Yellow	CAN High
White	0 Vdc

Color	T__A
Red	12/24 Vdc
Green	CAN Low
Yellow	CAN High
Black	0 Vdc



IP69K M12x1

mobile hydraulic technology ...

Order Code

1 3 C X X X X X X X X X X X X X X X X X X

Output

C01 = CANopen
J01 = SAE J1939

Baud Rate

0 = 1000 kBit/s 4 = 125 kBit/s
1 = 800 kBit/s 6 = 50 kBit/s
2 = 500 kBit/s 7 = 20 kBit/s
3 = 250 kBit/s 8 = 10 kBit/s

Node-ID

CANopen : hex 01 to 7F (default 7F)
SAE J1939 : hex 01 to FD (default FD)

Connection Type

N__A = pigtail (stripped conductors) no termination (20AWG)
N__F = 4 single wires , M12x1 IP69K,5pin (pin assignment 2-3-4-5)
Ex. : 06 = 60mm wire length
 25 = 250mm wire length

T__A = 4 wires integral PUR shielded cable, pigtailed
Ex. : 10 = 1.0 meter cable length (0.5 meter mini.)
 35 = 3.5 meter cable length

Sensor Styles

1 = 10mm dia. rod, damping zone 60mm
2 = 10mm dia. rod, damping zone 36.5mm
3 = 7mm dia. rod, damping zone 60mm

Magnet Type

1 = Outer dia. 33mm, inner dia. 13.5 ring magnet
2 = Outer dia. 25.4mm, inner dia. 13.5 ring magnet
3 = Outer dia. 17.4mm, inner dia. 13.5 ring magnet

Stroke Length (mm)

0075, 0100, 0125, 0150, 0175, 0200, 0225
0250, 0275, 0300, 0325, 0350, 0375, 0400
0425, 0450 (25mm increment after)



Installation Dimensions

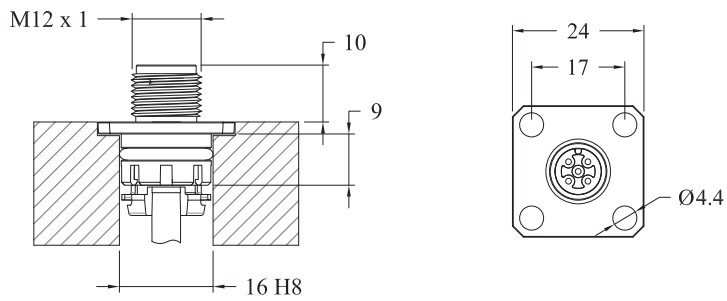
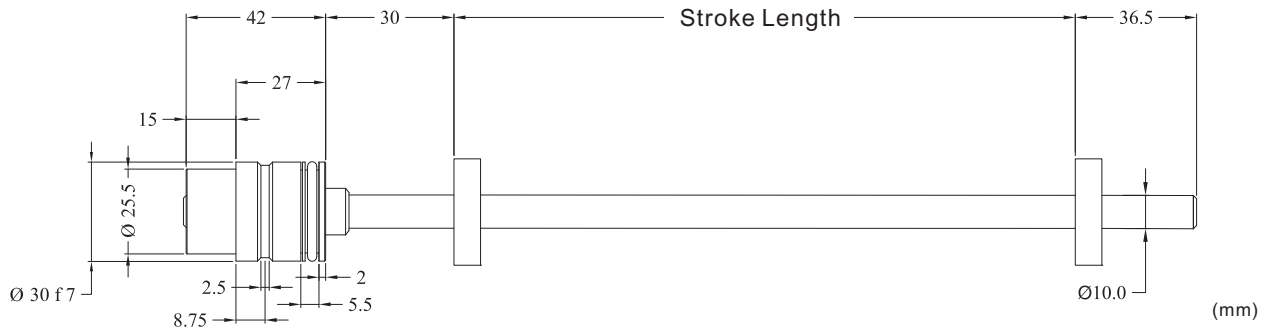

IP69K M12x1

Installation

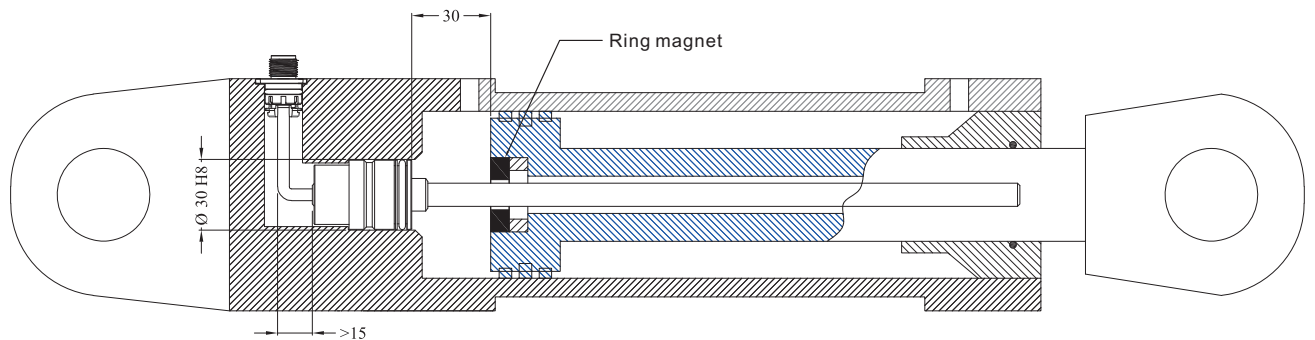

Remark

- 1) Use a non-ferrous circlip to fasten the magnet.
- 2) Minimum drilling for a 10mm rod should be 13.5mm.
- 3) No less than 3mm clearance between the end of the sensor rod and the bottom of the rod bore at full retraction.

Discription
Order Code

Outer Dia. 17.4 mm ring
1700 951 025

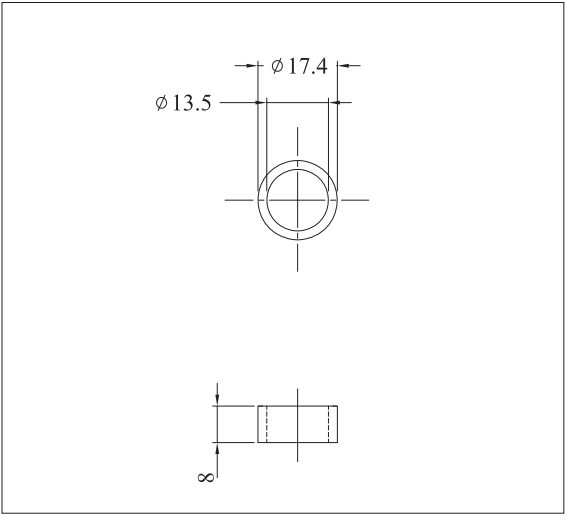

Material
Weight

Plastic
~4g

Outer Dia. 25.4mm ring
1700 951 023

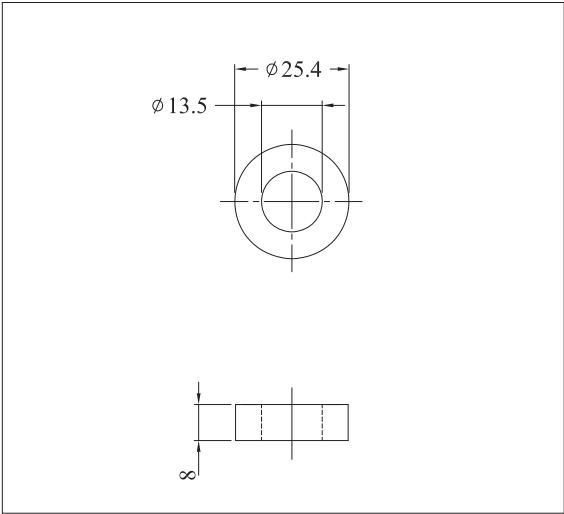

Plastic
~8g

Discription
Order Code

Outer Dia. 33mm ring
1700 951 001

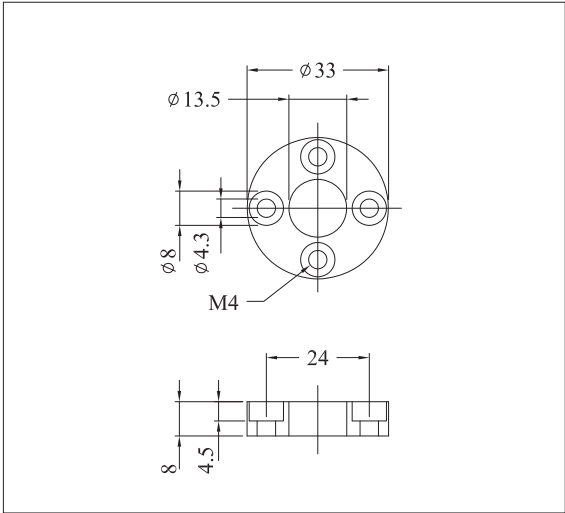

Material
Weight

Plastic
~8g

Discription
Order Code
Material

Dia. 33mm Spacer
1700 951 002
Plastic



M12 Connector

Profinet		Profinet Input	Profinet Output	24V Power Input
Model		4 pins M12 D-model male	4 pins M12 D-model male	4 pins M8 female
199 series D56	Order Code	1 800 951 041	1 800 951 041	1 800 951 040
199 series D58		Model	4 pins M12 D-model male	4 pins M12 A-model female
	Order Code	1 800 951 041	1 800 951 041	1 800 951 079
EtherCAT		EtherCAT / Profinet Input	EtherCAT / Profinet Output	24V Power Input
197 Series	Model	4 pins M12 D-model male	4 pins M12 D-model male	4 pins M8 female
	Order Code	1 800 951 041	1 800 951 041	1 800 951 040
Profibus		Profibus Input	Profibus Output	24V Power Input
195 series D53	Model	5 pins M12 B-model female	5 pins M12 B-model male	4 pins M8 female
	Order Code	1 800 951 063	1 800 951 064	1 800 951 060
195 series S13	Model	5 pins M12 B-model female	5 pins M12 B-model male	3 pins M8 female
	Order Code	1 800 951 063	1 800 951 064	1 800 951 084
195 series D63	Model	6 pins D60 female	6 pins D60 male	
	Order Code	1 800 951 010	1 800 951 066	
Canbus		Input	Output	24V Power Input
194 series D54	Model	5 pins M12 A-model female	5 pins M12 A-model male	4 pins M8 female
	Order Code	1 800 951 017	1 800 951 033	1 800 951 040
194 series S94	Model	5 pins M12 A-model female	5 pins M12 A-model male	
	Order Code	1 800 951 017	1 800 951 033	
194 series S92 / D34	Model	5 pins M12 A-model female		
	Order Code	1 800 951 017		
Analog		Output		
190 / 191 series D34	Model	5 pins M12 A-model female		
	Order Code	1 800 951 017		
190 / 191 series S15	Model	8 pins M12 female		
	Order Code	1 800 951 026		
Start Stop		Output		
17 / 18 series	Model	8 pins M12 female		
	Order Code	1 800 951 026		
Analog Output		Output	Output	
17 / 18 series	Model	5 pins M12 A-model female	5 pins M12 A-model 90deg female	
	Order Code	1 800 951 017	1 800 951 018	



*Cable Dia. 6-8mm

D60 / D70 / S32 Connector

Discription	Straight Connector (female)		
Model	D60	D70	S 32 (8 pin)
Order Code	1800 951 010	1800 951 012	1800 951 069
Material	Cu Zn / Plastic		



Straight
Length: 55mm

Discription	90° Degree Connector (female)		
Model	D60	D70	S 32 (8 pin)
Order Code	1800 951 011	1800 951 013	1800 951 090
Material	Cu Zn / Plastic		



90 Degree
Length: 55mm

Fieldbus Terminator

CANbus	Model	CANbus D62 terminator
194 series	Order Code	1800 951 044

Profibus	Model	Profibus D53 terminator
195 series D53	Order Code	1800 951 043

Profibus	Model	Profibus D63 female terminator
195 series D63	Order Code	1800 951 028
		Profibus D63 male terminator
		1800 951 068

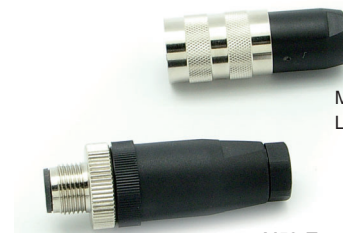

M63 Female Terminator
Length: 45mm

M53 Terminator
Length: 47mm

high precision & reliability...

16 series

1 8 0 0 9 5 X X X X X

Connector

1 2 = D60 straight female
1 6 = D60 90 degree female

1 7 = D70 straight female
1 8 = D70 90 degree female

1 4 = 5 pins M12 A model female
2 3 = 5 pins 90deg. M12 A model female

2 4 = 8 pins M16 female (S32,SSI)
2 5 = 8 pins M16 female (S32,voltage)
2 6 = 8 pins M16 female (S32,current)

Cable Length

Select the cable length in unit Meter
For example, 01 = 1 Meter

Cable Type

R = PVC cable T = Teflon cable
H = PUR cable W = Waterproof cable

*shield twisted pair cable 3 x 2 x 0.2mm²

D60	
Color	female (#12/16)
Black	1
White	2
Yellow	3
Green	4
Red	5
Blue	6

5pins M12 A female (#14/23)		
Color	voltage	current
Black	2	2
White	5	5
Yellow	N	N.C.
Green	N.C.	N.C.
Red	1	1
Blue	3	3

D70 (#17/18)	
Color	female
Black	1
White	2
Yellow	3
Green	4
Red	5
Blue	6

*for SSI

8pins M16 female			
Color	S32 voltage (#25)	S32 current (#26)	S32 SSI (#24)
Black	5	1	5
White	2	2	2
Yellow	3	3	1
Green	N.C.	N.C.	3
Red	7	7	7
Blue	6	6	6

13 series

1 8 0 0 9 5 X X X X X

Connector

3 7 = 5 pins M12 female A (N__E)
3 8 = 5 pins M12 female A (N__G)
3 9 = 5 pins M12 female A (N__H)
4 0 = 5 pins M12 female A (CANbus)

Cable Length

Select the cable length in unit Meter
For example, 01 = 1 Meter

Cable Type

R = PVC cable T = Teflon cable
H = PUR cable W = Waterproof cable

*shield twisted pair cable 3 x 2 x 0.2mm²

Cable	N__E (#37)	N__G (#38)	N__H (#39)	N__F (#40)
Black	4	4	2	5
White	N.C.	N.C.	N.C.	4
Yellow	N.C.	N.C.	N.C.	N.C.
Green	N.C.	N.C.	N.C.	N.C.
Red	2	1	1	2
Blue	3	3	3	3

Model Cable with male connector (6 pin), straight - M12 A-coded male connector (5 pins) with flange

Order Code 1800 951 087

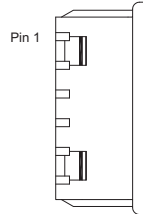
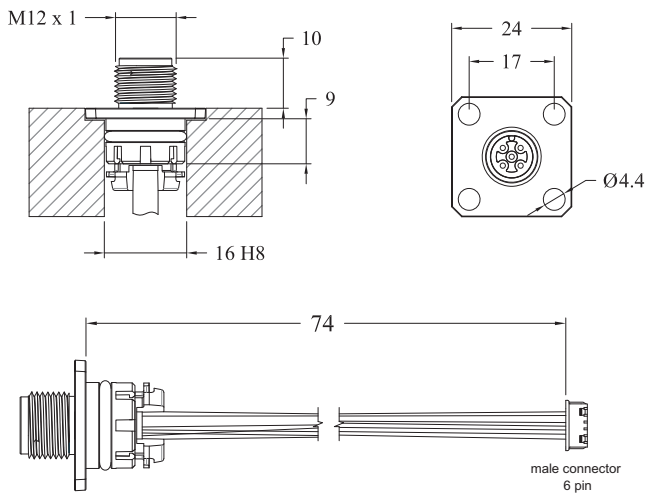

Pin		Pin
1	↔	4
—	↔	—
3	↔	2
4	↔	3
5	↔	5
6	↔	1

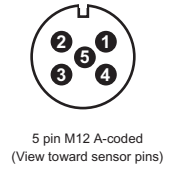

Model Extension cable, male connector (6 pin), straight - pigtail

Order Code 1800 951 086

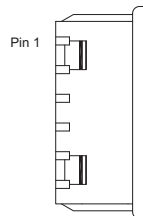
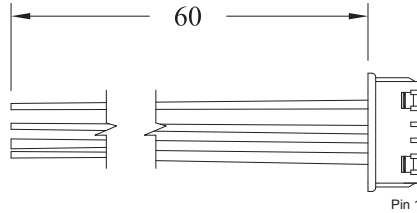

Pin		Color Code
1	↔	Yellow
—	↔	—
3	↔	Gray
4	↔	White
5	↔	Black
6	↔	Red

Model Extension Cable with male connector (6 pin), straight - female connector (6 pins) straight

Order Code 1800 951 088

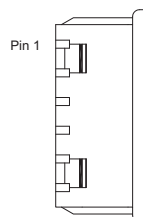
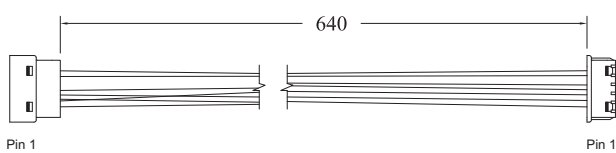

Pin		Pin
1	↔	1
2	↔	2
3	↔	3
4	↔	4
5	↔	5
6	↔	6

